

## SPEAKER POSITIONING

I have published a number of articles, in the past, about speaker positioning. We seem to have moved a long way, in the last fifteen years, in terms of recommended speaker positioning. The rule of 'thirds' is no longer religiously accepted nor applied. The rule of thirds dictates that the speakers must be on a line across the room, one third of the distance down it and each speaker must be one third of the room width away from the walls. One then had to sit twice the distance away from the speakers as they were apart which should, if my arithmetic is correct, put you against the rear wall of the room. The rule of thirds will put your speakers in positions of least interaction with the room and also, apart from your sitting against the rear wall, in the location of least bass.

I think I mentioned before, but am too lazy to check, that the most bass, in volume but worst in quality, is in the corners of the room. Try an experiment. Leave your speakers where they are and sit in a corner close to the walls. The bass will increase in volume but will become boomy. This will illustrate the effect of the room on sound.

Assuming your speakers are not designed to stand against the wall (which to me indicates a design flaw anyway) you can ascertain the best location by making a to scale sketch of your room and dividing it into quarters and thirds. To do this divide the length and width of the room with two equidistant lines each (thirds) and three lines each (quarters) where the lengthwise and widthwise quarter lines intersect your speakers will have the most bass (other than in the corners and against the walls) and where the thirds lines intersect, the least. Measure these locations on the floor of your room. Now, using a piece of masking tape or similar, join the quarter intersects with the third intersects. You will see that there is little distance between them which explains why small changes in location often produce big changes in sound. When I refer to the distance of the speaker from the side walls I am measuring from the middle of the bass driver. The bass driver interacts with the room much more than the tweeter. In terms of distance from the front wall (facing the listener) I am referring to the distance from the wall to the apex of the bass driver cone.

Now place your speakers in the quarter intersect locations using the focal points as described in the paragraph on measurement above. Play a selection of familiar music and note the sound. The main quality to note is that of the bass and midrange. Is the bass heavy and ponderous or natural and melodious? Is the bass boomy, thick or too loud or is it tight and well-defined? Now move the speakers to the thirds location and go through the same routine. Is the bass thin and light? Does it have extension or does it roll off before deep bass is heard? In this way you will have defined the audio extremities. With a bit of luck one of the locations will suite you. Without a little bit of luck, assuming that neither location is your ideal, move the speaker slowly along the line between the thirds and quarter intersects until you are happy. If you do this properly you can play with positioning until Christmas when you can play with some other new toys.

*See sketch below:*

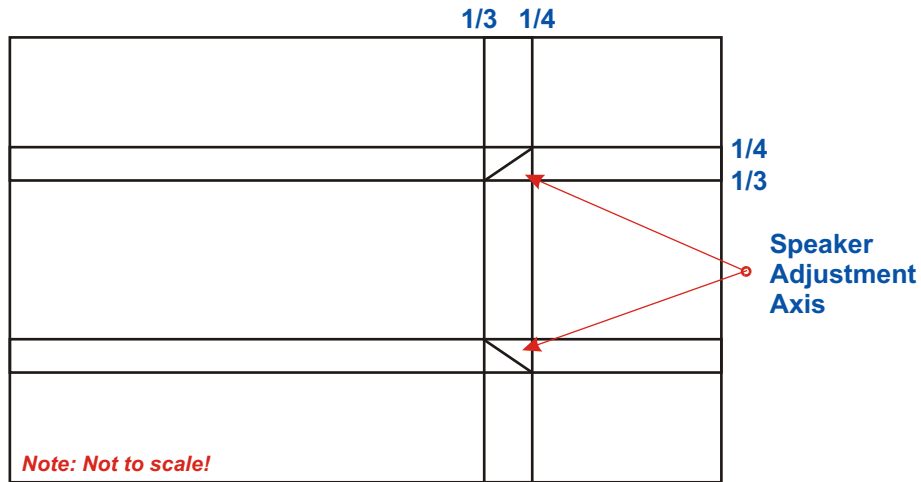

Now we are going to set the toe-in of the speakers. In this case, the tweeter is in the limelight. Tweeters are generally directional while the bass is omni-directional. Why this is so is a whole new story and I will not go into it now.

In order to set the toe-in of your speakers (how much they are turned in toward the listener from a straight ahead position) make a grid of masking tape around the speaker. No! it won't harm the carpet. Using one of the corners of the speaker enclosure as a reference point mark its present position on the masking tape. Now turn the speakers in or out, depending where you had them before, a small amount, equal on both sides, and mark the new position. Now judge whether the sound quality has improved or deteriorated. Some tweeters sound best when fired directly at your ears (horizontally on axis) others when toed out off-axis. I read an article recently that suggested that all speakers should be toed in so that their axes cross in front of the listener. I don't buy that one but try it anyway. Some tweeters sound sharp, gritty and aggressive on-axis whereas others sound resolving and focussed.

Play around, try them all, have fun.

